



KLIXON®

PHENOLIC MOTOR PROTECTORS

WHY PROTECT MOTORS?

Overheating of motor insulation causes reduction in dielectric strength which can result in motor insulation damage or failure. The following are causes of motor overheating for which Klixon motor protectors can be applied to achieve protection:

- Prolonged running overload
- Locked rotor: mechanical / electrical failure to start
- Low line voltage
- High ambient temperature and lack of ventilation

Features

- Normally closed “make or break” Klixon® contact system, which is operated by a snap action disc, is sensitive to both temperature and current.
- Precision calibration – temperature calibrated and inspected under controlled conditions for dependable performance.
- Automatic or manual reset series available
- Easy to install
- UL recognized E15962
- CSA certified LR11372
- VDE certificate with production surveillance, overheating protector. 37 amperes maximum locked rotor 230 VAC, File 4464.4-4510-1013, License No. 3938 UG for 3/4” M.P. only.
- Inherent protection devices for approximately 1/2 to 5 h.p. motors used in applications such as industrial motors, agricultural equipment, well and sump pumps, fans, air conditioners, refrigerators, home appliances, etc.
- When properly applied, protector shuts off motor when temperature exceeds maximum safe level due to an overload or stalled (locked rotor) condition.

Klixon Phenolic Motor Protectors are equipped with a bimetallic snap acting disc, on which the contacts are mounted, and through which the current flows. If overheating conditions occur, the heating effect of the current flow through the Klixon disc and the influence of motor heat will cause the disc temperature to rise.

When the disc reaches the calibrated setpoint, the Klixon protector automatically opens and shuts down the motor, limiting the winding and shell temperature.

When the motor has cooled to an acceptable operating level, allowing the protector to cool to its reset temperature, the Klixon protector resets automatically to a closed contact position allowing the motor to restart.

Manual reset versions are also available for applications where automatic restarting may be hazardous to equipment or operations.

Automatic Reset Exploded View

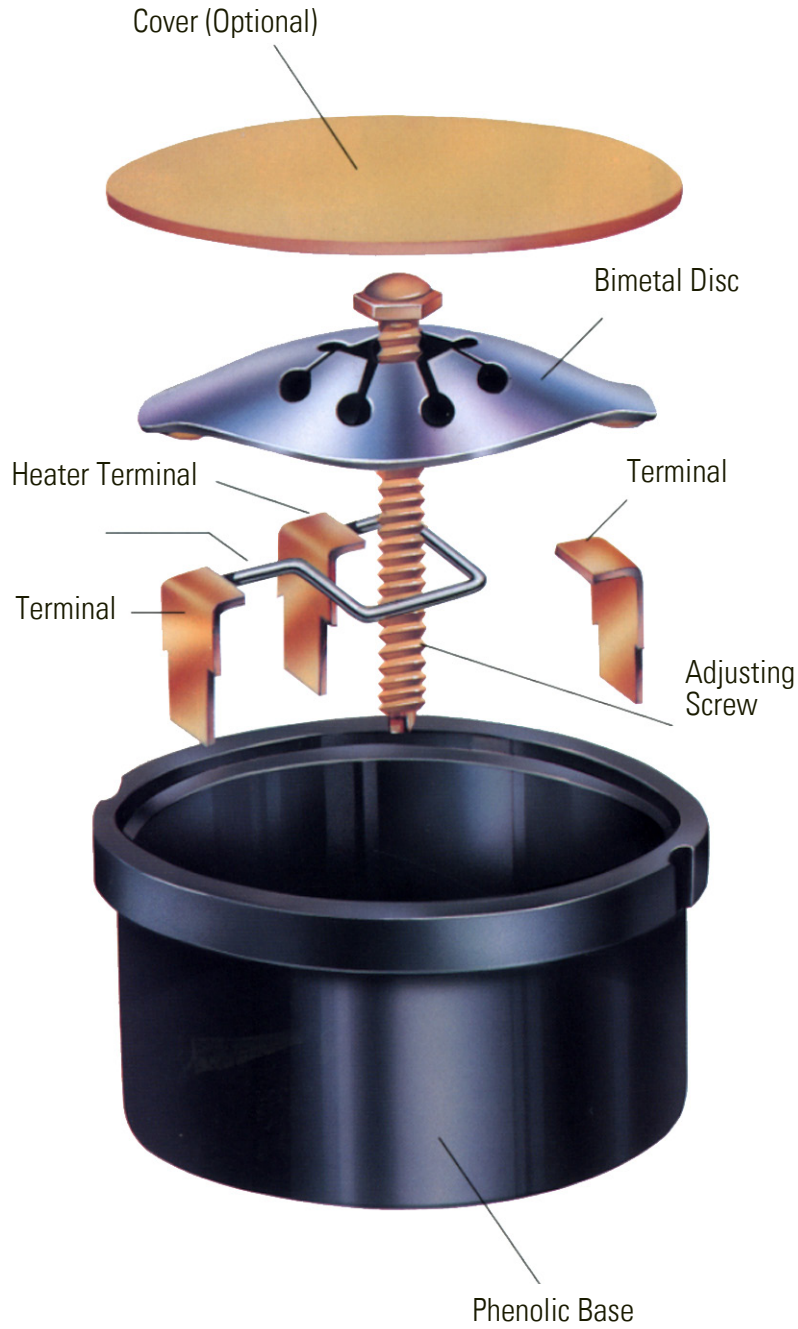

Contacts Open

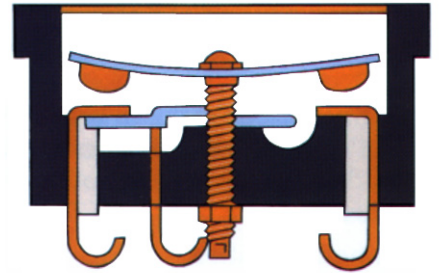

Contacts Closed

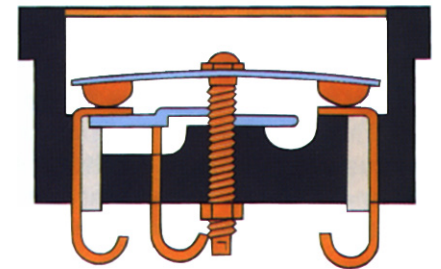

Manual Reset

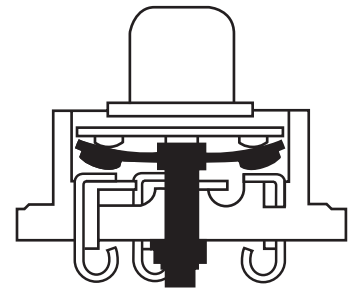

Dimensional Drawings (Single Phase Types)

Round Base

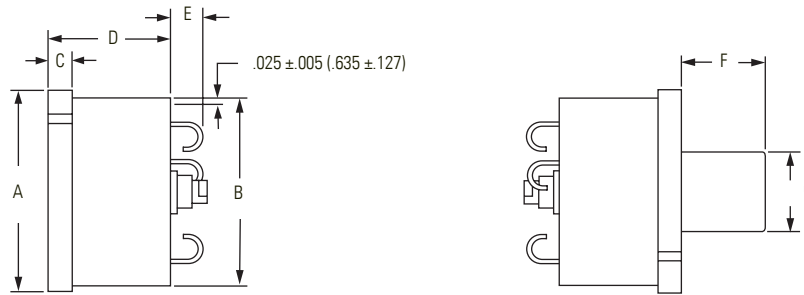

Type	Size	A	B	C	D	E Max.	F	G
MR	3/4"	1.031 ±.010	.970 ±.006	.125 ±.005	.625 ±.010	.171	23/64 ±1/32	.375 ±.006
CR	1"	1.312 ±.010	1.218 ±.010	.125 ±.005	.640 ±.010	.218	31/64 ±1/32	.442 ±.006
BR	1 1/4"	1.640 ±.010	1.555 ±.010	.156 ±.010	.930 ±.015	.313	27/64 ±1/32	.442 ±.006
LR	1 1/2"	1.983 ±.010	1.881 ±.010	.154 ±.010	.830 ±.015	.375	15/32 ±3/64	.781 ±.006

Eared Base

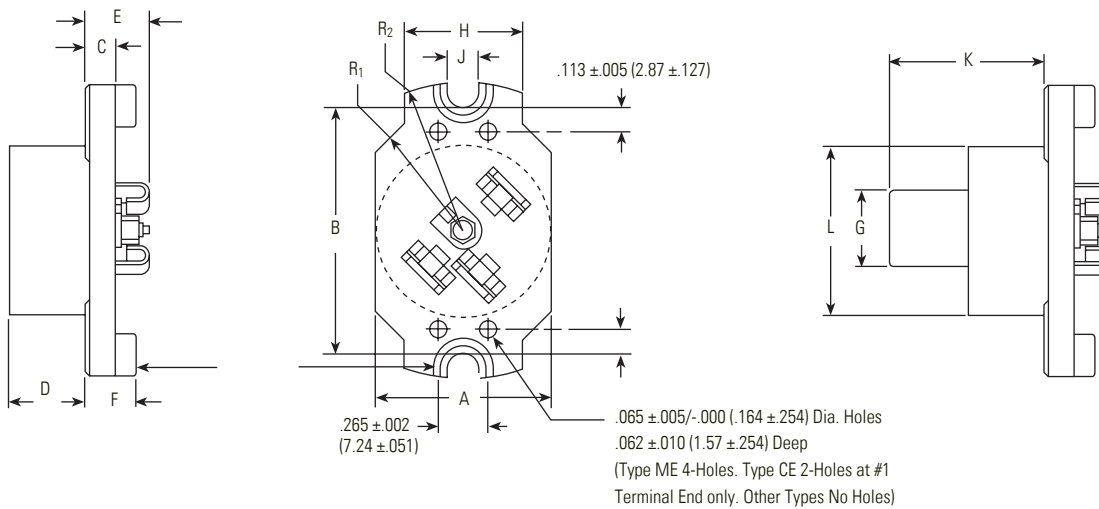

Type	Size	A	B	C	D	E	F	G	H	J	K	L	R ₁	R ₂
ME	3/4"	.970 ±.010	1.390 ±.015	.175 ±.010	.450 ±.015	.354	—	.436 ±.007	.625 ±.010	.176 ±.010	.953	.970 ±.006	.656 ±.010	.845 ±.010
CE	1"	1.187 ±.010	1.390 ±.015	.175 ±.010	.464 ±.015	.406	—	.440 ±.008	.625 ±.010	.176 ±.010	1.000	1.187 ±.010	.656 ±.010	.845 ±.010
BE	1 1/4"	1.594 ±.010	2.125 ±.010	.223 ±.010	.715 ±.010	.552	.332 ±.010	.440 ±.008	1.000 ±.010	.218 ±.010	1.180	1.552 ±.010	.844 ±.010	1.344 ±.010
LE	1 1/2"	1.875 ±.010	2.125 ±.020	.267 ±.010	.890 ±.010	.683	.517 ±.010	.781 ±.006	1.250 ±.010	.218 ±.010	1.370	1.875 ±.010	1.000 ±.010	1.344 ±.010

Type Code Structure for Single Phase Phenolic Motor Protectors

The following is an explanation of the type code which appears on each standard Klixon phenolic motor protector. By using this code, it is possible to determine the following size, type of base, terminals, heater, disc and contacts type and operating temperature.

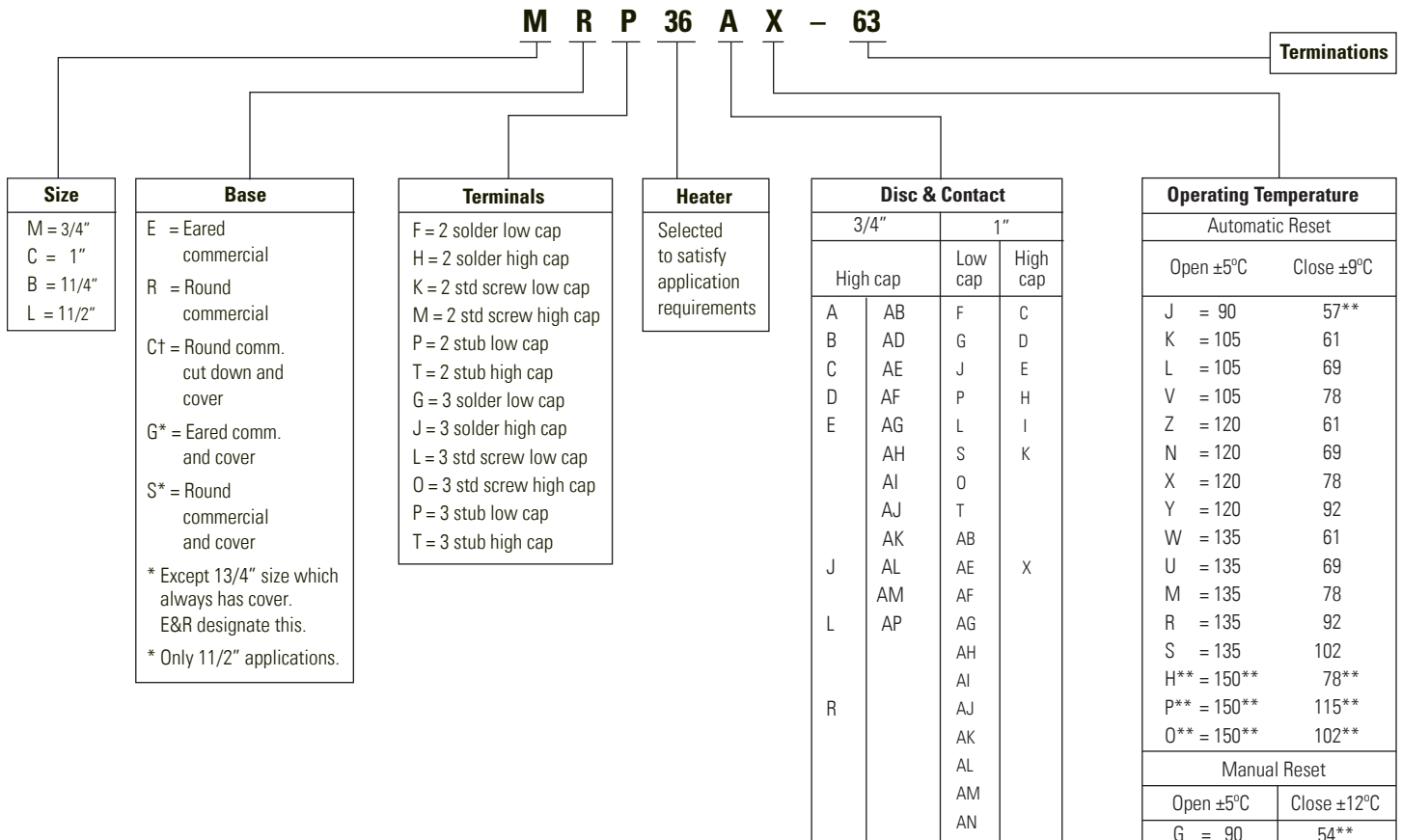

Maximum Recommended Protector Contact Ratings

This chart is used to determine protector size needed when making an application.

Size	Disc Contacts	Terminals	Max. Current V = 120	Max. Current V = 240
3/4"	HC	LC	32	25
3/4"	HC	HC	50	37
1"	LC	LC	40	30
1"	HC	LC	40	30
1"	LC	HC	40	30
1"	HC	HC	80	60
1 1/4"	STD	STD	135	100
1 1/2"	STD	STD	175	130

HC = High Capacity **LC** = Low Capacity **STD** = Standard Capacity
For reference only. Please contact Sensata for application assistance.

* 1-Phase Protectors only.
** Special temperatures. Consult net additions.
*** 3-Phase Protectors only.

Application Worksheet

A sample worksheet provides the information needed for a proper application. It is not possible to apply a Klixon protector based on horsepower, amperage, or name plate data only.

Motor Data

A. Locked Rotor Requirements

1. Locked Rotor Current Cold: the current which exists the instant the motor is turned on.
2. Locked Rotor Current Hot: The current level that exists at end of 1st cycle test. Typically 10 to 30 seconds after motor is first turned on.
3. Time elapsed during above test to raise motor winding temperature from room temperature to around maximum allowed temperature for the UL class of motor insulation. An example would be, for a class A motor, 25°C to 175°C in 12.5 seconds.
4. Ambient Temperature During test: Room temperature (usually 25°C).

B. Running Overload Requirements

1. Load Current: With the motor running, the load on the motor is to be increased in small increments until the motor winding has completely stabilized at approximately 10°C below the maximum allowed by the UL class of the motor. An example would be, for a class A motor, the maximum allowed is 140°C. The motor winding temperature was completely stabilized at 130°C and the current draw at that time would be recorded.
- 2&3. Protector Location Temperatures: These temperatures are taken at the conclusion of the above load current test while the motor is running under the above load.
4. Ambient Temperature: Room temperature (usually 25°C).

C. Abnormal Conditions for Protection.

1. Max/min Ambient Temperatures: temperature in the surroundings of protector.
2. Max/min Line Volts: The highest and lowest voltages for which protection should be effective.
3. Other environmental considerations: i.e., exposed to agricultural weather conditions.

Name Plate Data

- | | | |
|---|-------|-------|
| A. Horsepower | _____ | H.P. |
| B. Voltage | _____ | Volts |
| C. Single or three phase | _____ | Phase |
| D. FLA (full load amps) | _____ | Amps |
| E. LRA (locked rotor amps) | _____ | Amps |
| F. Insulation class (UL/CSA) (indicate one) | _____ | ABFH |

Protector Requirements

- | | |
|------------------------------|-------|
| A. Automatic or manual reset | _____ |
| B. Round or eared base | _____ |
| C. Termination type | _____ |

Motor Data Required

- | | |
|--|-------------|
| A. Locked rotor requirements | |
| 1. Locked rotor current cold | _____ Amps |
| 2. Locked rotor current hot | _____ Amps |
| 3. Time required to raise motor winding to max. temperature | _____ Sec |
| 4. Ambient temperature during test | _____ Deg |
| B. Running overload requirements | |
| 1. Load current required to stabilize main winding temp. at 10°C below maximum allowed | _____ Amps |
| 2. Protector location temperature below protector surface | _____ Deg |
| 3. Protector location temperature above protector (air temp) | _____ Deg |
| 4. Ambient temp during test | _____ Deg |
| C. Abnormal conditions for protection | |
| 1. Max/min ambient temperatures | _____ Deg |
| 2. Max/min line volts | _____ Volts |
| 3. Other environmental considerations | _____ |

Note: Application assistance available from Sensata.

Example of Motor Protector Performance Curves

**Ultimate Trip Current
vs
Protector Ambient Temperature**
(Approximate, to be used only for selecting samples for motor verification test)

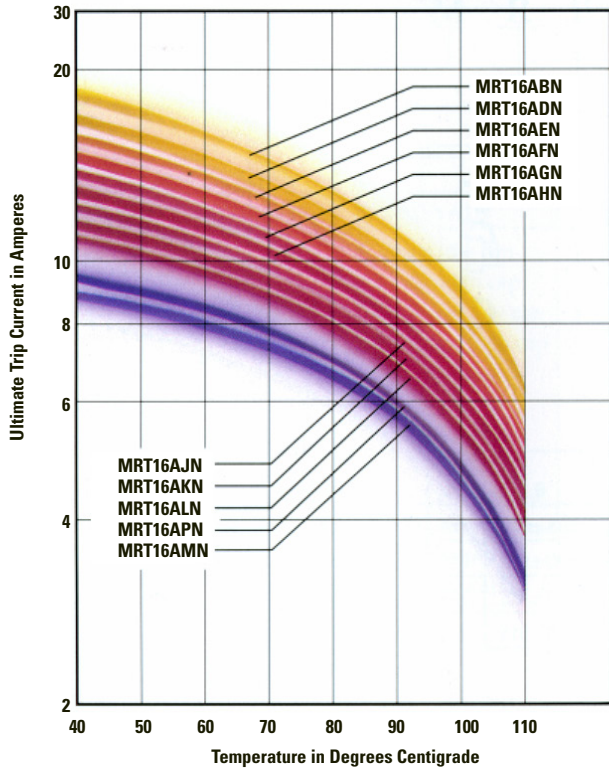

**Average first Cycle Tripping Time
vs
Current in 25°C Ambient**
(Approximate, to be used only for selecting samples for motor verification test)

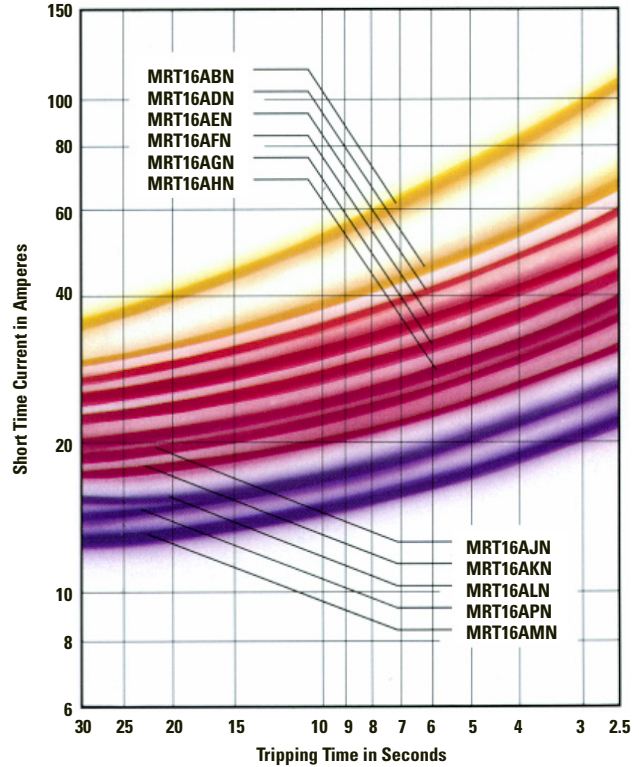

Note: Other ratings available for single and three phase applications.
Computer software is available to assist in application.



Sensata Technologies
529 Pleasant Street
Attleboro, MA 02703-2964
Phone: 1 (508) 236-3800
Email: klixon@sensata.com
Web: www.sensata.com

Important Notice: Sensata Technologies (Sensata) reserves the right to make changes to or discontinue any product or service identified in this publication without notice. Sensata advises its customers to obtain the latest version of the relevant information to verify, before placing any orders, that the information being relied upon is current. Sensata assumes no responsibility for infringement of patents or rights of others based on Sensata applications assistance or product specifications since Sensata does not possess full access concerning the use or application of customers' products. Sensata also assumes no responsibility for customers' product designs.