

# TEXAS INSTRUMENTS 4GS Duct Mount Kit Assembly Instructions (4GS-DM-KIT)

READ THIS ENTIRE MANUAL BEFORE PROCEEDING. Failure to follow this procedure may cause unreliable sensor operation or may cause permanent damage to either the duct mount box or the 4GS sensor unit.

1. Select a plastic knock-out disk on the duct mount box (4) to be used for installation of the strain relief assembly (10). *Carefully remove the center portion of the plastic knock-out disk only.*
2. Insert the insulator (12) into the strain relief assembly base (10), and loosely screw the cap on. Securely attach the entire strain relief assembly to the duct mount box (4) with the lock nut (11), ensuring that the end with the internal serrations faces outward.
3. Attach the seal gasket (6) and washer (9) to the venturi tube (5), using a #12 screw (8). *Do not over-tighten the screw.*
4. Carefully slide the mount gasket (7) over the notched end of the venturi tube (5). *Care must be taken so as not to tear the gasket on the edges of the tube.*
5. Pass the notched end of the venturi tube into the hole on the back of the duct mount box (4). Secure the venturi tube to the

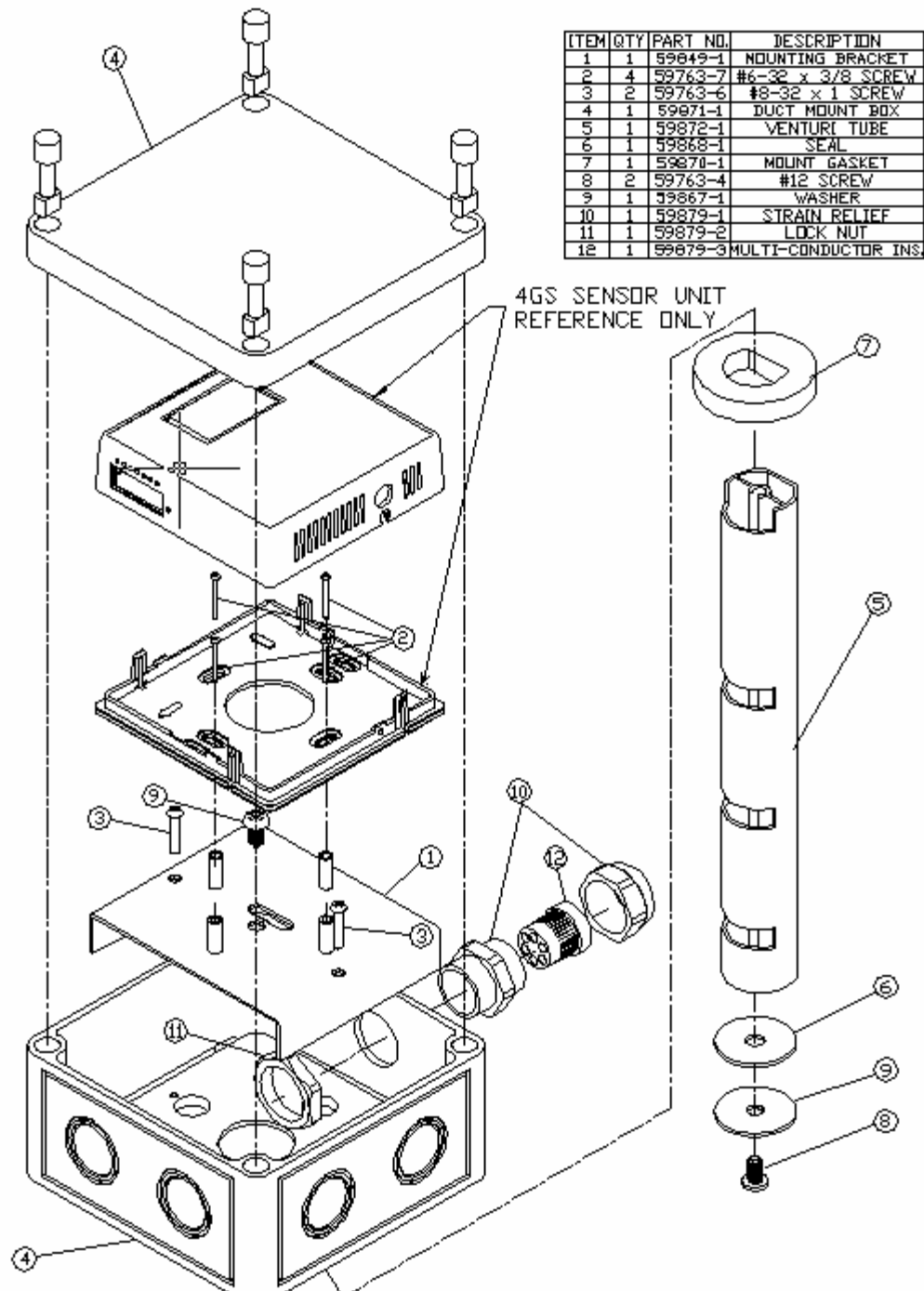

mounting bracket (1) using the 2nd #12 screw (8). Ensure that the raised portion of the notch on the venturi tube properly carries up with the oblong opening of the mounting

bracket (1). *Do not over-tighten the screw.* Now slide the mount gasket (7) until it is flush-up against the back of the duct mount box.

6. Attach the duct mount box assembly to a prepared duct by passing the four enclosed 11/2" sheet metal screws through the four corners of the duct mount box. *The round holes on the venturi tube must face into the duct's air-flow in order for the sensor to work properly.*
7. Run the necessary wires through the insulator (12), and fill the unused holes of the insulator with silicon caulking so that it is airtight. Then, securely tighten the screw cap of the strain relief (10) to ensure unit airtight integrity.
8. Attach the back-plate of the 4GS sensor to the mounting bracket using the four #6 screws (2). Then, install the 4GS sensor to the wires and back-plate as described in the 4GS sensor manual.
9. Attach the duct mount box cover using the four black-plastic screws (enclosed), and the unit is now ready for operation.

the latest version of the relevant information to verify, before placing orders, that the information being relied upon is current.

Texas Instruments assumes no responsibility for infringement of patents or rights of others based on Texas Instruments application assistance or product specifications since TI does not possess full access concerning the use or applications of customers' products. TI also assumes no responsibility for customers' product designs.

Questions regarding maintenance, care or replacement of parts for the TI 4GS Duct Mount Kit should be directed to 1-888-438-2214 or email [tisensors@ti.com](mailto:tisensors@ti.com).

Be sure to visit our website at:

**[www.ti.com/snc/products/sensors/gas.htm](http://www.ti.com/snc/products/sensors/gas.htm)**

## Application Notes

**IMPORTANT NOTICE:** Texas Instruments (TI) reserves the right to make changes to or discontinue any product or service identified in this publication without notice. TI advises its customers to obtain