



## DPS SERIES

### MEMS Piezoresistive Differential Pressure Sensor Voltage Output, High Accuracy, Hermetic

#### WORLD CLASS PERFORMANCE

The Sensata DPS Series pressure sensors are ideally suited for environmentally demanding automotive and heavy vehicle/off road applications. Using a 5V excitation input, the DPS series sensors provide a .5-4.5V output signal proportional to differential pressure in diesel exhaust streams. This design requires no end user amplification. Custom packaging options are available.

Sensata Technologies has been a leading global supplier of pressure sensors & switches for over 50 years.

#### Features & Benefits

- Linear output ratiometric with supply
- Total error band  $\pm 2\%$  full scale
- Broad operating temperature range (-40°C to +135°C)
- EMC protection to >200 V/m
- EEPROM calibration and serialization
- On board error diagnostics
- Custom packages available

#### Applications

- Diesel Particulate Filter
- Venturi Flow Meter
- Air Filter Restriction
- Engine Controls & Monitors

#### Markets

- Automotive
- Agriculture & Construction Equipment
- Diesel Engines

#### Product Technology

The DPS Series transducer employs a pressure sensitive silicon MEMS diaphragm with embedded piezoresistors connected in a four terminal bridge. Deformation of the diaphragm changes the resistance of the elements and bridge output voltage. The integrated MEMS construction enables high signal output, low hysteresis, and rapid response time. Proprietary noble metal conductors, gel encapsulation, ceramic PCB mount, and isolation of signal conditioning electronics, permit reliable operation in severe media. The transducer operates on a 5 Vdc supply, and provides a linear voltage output. With the added benefits of digital temperature compensation, EEPROM memory, and self diagnostic capability, it is ideal for applications demanding premium accuracy and reliable performance.

#### Technical Specifications

<b>Pressure Ranges Available</b>	<b>Electrical</b>
0-18, 35,100 kPaD	Supply Voltage ..... 4.75 to 5.25 Vdc
<b>Performance</b>	Output range ..... 0.5 to 4.5 Vdc
Accuracy..... $\pm 2\%$ F.S. typ (Total Error Band)	Supply Current ..... 10 mA max
Thermal Effect on Offset ..... $\pm 0.008\%$ F.S./°C (-15°C to 100°C)	Overvoltage Protection ..... +16 V
Thermal Effect on Span ..... $\pm 0.003\%$ F.S./°C (-15°C to 100°C)	Reverse Voltage Protection ..... -14 V
Operating Temperature ..... -40°C to +135°C	EMC (to 1 GHz) ..... 100 V/m
Storage temperature ..... -40°C to +140°C	ESD ..... 15 kV
<i>Custom packaging available</i>	<b>Physical</b>
	Proof Pressure ..... > 2x F.S.
	Burst Pressure ..... > 3x F.S.
	Drop (any axis) ..... 1m
	Random Vibration (20-2000 Hz) ..... 16Grms

## Typical Dimensions (mm)

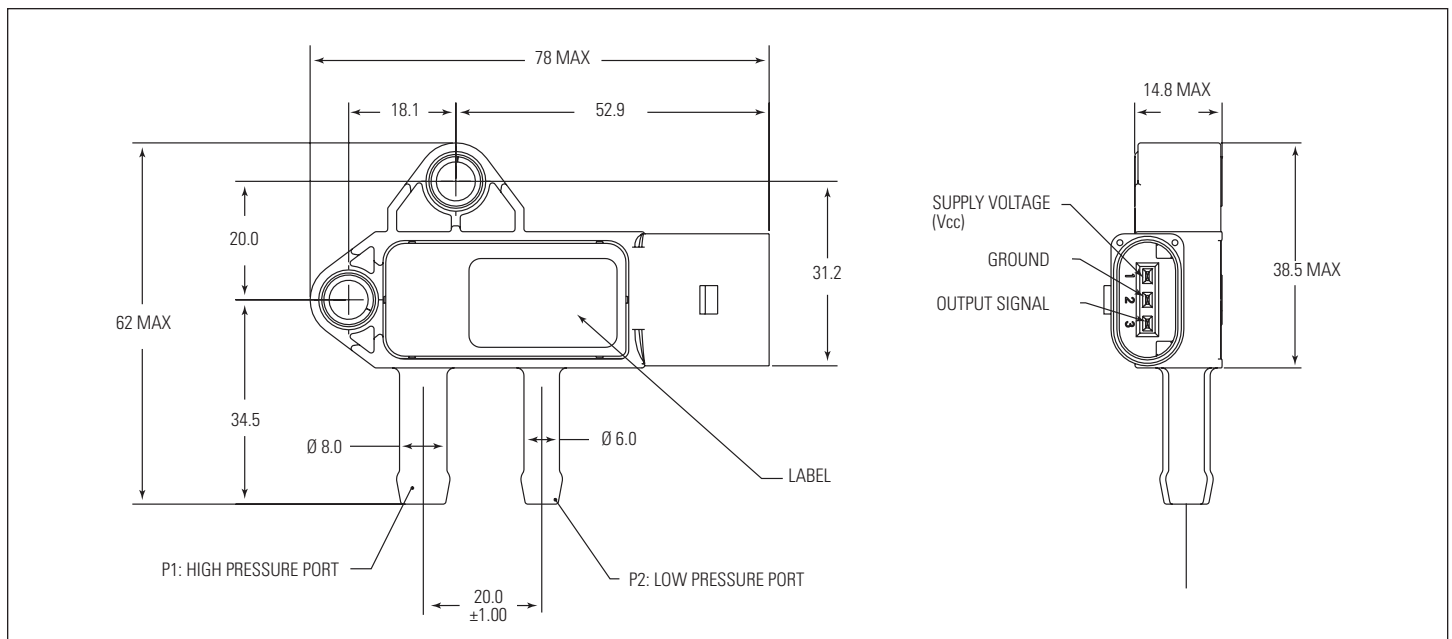

## Typical Product Qualification Tests:

- Thermal Cycling
- High Temperature Endurance
- Low Temperature Endurance
- Vibration
- Humidity
- Salt Spray
- Corrosive Media

## Standard Product Offerings

Specifications	Part #
100 kPa	1 MPP2-2
35 kPa	1 MPP2-1
18 kPa	1 MPP2-3

## Nominal Output Characteristics

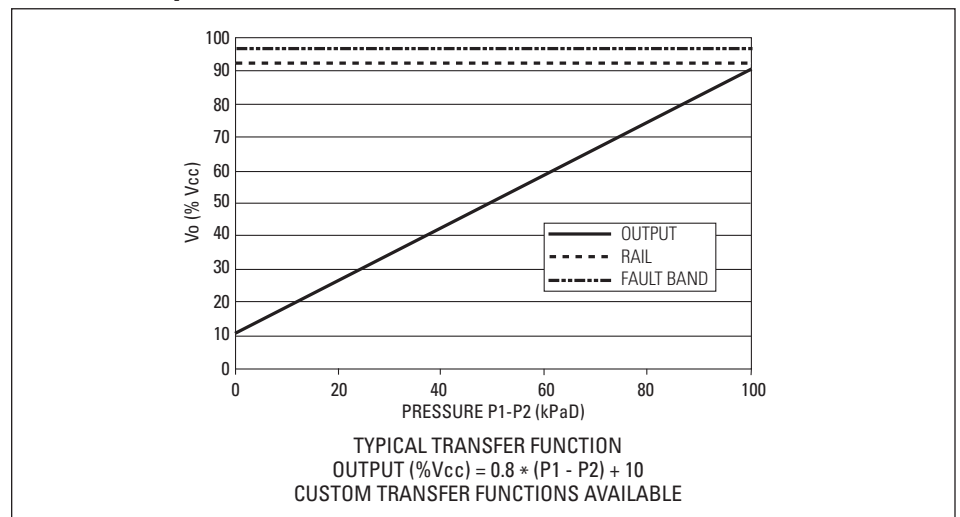

## Competitive Advantages

Sensata	Competitors	Sensata Advantage
Single sensing die	Two sensing dies	Superior accuracy
Noble metallization	Aluminum metallization	Superior corrosion resistance
Gel protection	Metal diaphragm / oil fill	Superior thermal error
Conditioning electronics isolated from media	Conditioning electronics on chip exposed to media	Superior reliability
Open backside geometry	Constrained backside geometry	Superior resistance to ice damage



## Sensata Technologies

529 Pleasant Street  
 Attleboro, MA 02703-2964  
 U.S.A.  
 Phone 1-508-236-3800  
[www.sensata.com](http://www.sensata.com)

Important Notice: Sensata Technologies (Sensata) reserves the right to make changes to or discontinue any product or service identified in this publication without notice. Sensata advises its customers to obtain the latest version of the relevant information to verify, before placing any orders, that the information being relied upon is current. Sensata assumes no responsibility for infringement of patents or rights of others based on Sensata applications assistance or product specifications since Sensata does not possess full access concerning the use or application of customers' products. Sensata also assumes no responsibility for customers' product designs.